

General Instructions for Operation, Installation and Maintenance

FIREPLACE INSERT

HAAS + SOHN Rukov s.r.o.



MANUFACTURER:

HAAS+SOHN

SNP 474, 408 01 RUMBURK, CZECH REPUBLIC
COMPANY ID: 62740989 TAX ID: CZ62740989

JK 06 185 16 04 14 09 e

CONTENTS

1. TECHNICAL SPECIFICATIONS	4
1.1. General requirements on fireplace insert installations.....	4
1.2. Heating concept.....	4
1.3. Construction design.....	5
2. FIRING PROCESS	5
2.1. Fuel quantity and firing process adjustments.....	5
2.2. Fuel.....	6
3. SAFE OPERATION	6
3.1. General requirements.....	6
3.2. Safe distance between the fireplace insert and flammable material.....	7
3.3. Safe distance between the smoke flue and flammable material.....	7
3.4. Directions for safe operation.....	7
4. INSTALLATION AND CONNECTION TO THE CHIMNEY	7
4.1. Connection to the chimney or chimney insert.....	7
4.2. Connecting the stove insert to the venting unit.....	8
4.3. Directions for smoke flue installation and safety.....	8
4.4. Installation of the fireplace insert within the room.....	8
4.5. Cleaning the heating device and chimney.....	9
4.6. Fire in the chimney.....	9
4.7. External combustion air supply.....	9
4.8. External air supply system.....	9
5. OPERATING INSTRUCTIONS	9
5.1. Before first operation.....	9
5.2. Setting the fire.....	10
5.3. Feeding the fire.....	10
5.4. Glass cleanness.....	11
5.5. Operation during temporary period and at worsened weather conditions.....	11
5.6. Fireplace insert function adjustment.....	11
5.7. Ash removal.....	11
6. CLEANING AND MAINTENANCE	12
6.1. Cleaning.....	12
6.2. Sealing lines and tapes.....	12
6.3. Spare parts.....	12
7. WHAT TO DO IF... DO YOU DO IT YOURSELF?	13-14
8. FREQUENT PROBLEMS AND QUESTIONS	14
8.1. Cracked (released) fireclay (vermiculite) brick in the burning area.....	14
8.2. Broken glass.....	14
8.3. Partitions to control the chimney effect.....	14
8.4. Blind element substituted with exchanger (optional).....	15
9. PRODUCT LIABILITY AND SERVICE	15
9.1. General.....	15
9.2. Conditions for guarantee.....	15
9.3. Guarantee and post-guarantee service.....	15
9.4. Claim rejected.....	15
9.5. How to make a claim.....	15
9.6. How to order spare parts.....	16
10. MISCELLANEOUS	16
10.1. Accessories supplied with the insert.....	16
10.2. Special accessories (on order).....	16
10.3. Recommended spare parts.....	16
10.4. Package and waste disposal.....	16
10.5. ES Declaration of Conformity and CE Certificate.....	17

10.6. HAAS+SOHN Rukov s.r.o Products and Manufacturing Programme.....	17
11. SUPPLEMENTS.....	17-19

Congratulations! You have just bought the fireplace insert HAAS + SOHN, a top-quality product. Thank you very much for your interest and purchase. Kindly read the Manual to find out about the function, correct use and handling. We recommend you to read the instructions carefully in order to avoid any risk related to likely damage. Proper operation and maintenance affects the service life of the product as well. In addition, proper operation and fuel supply is connected with fuel savings and environment protection. The technical specifications are shown in the Technical Card (included in the booklet).

The manufacturer provides guarantee providing you adhere to the directions and recommendations in the instructions for operation and maintenance. Keep the Operating Instructions and the Technical Card safe to be able to refresh your knowledge at the beginning of the new heating season.

The General Instructions for Operation, Installation and Maintenance are valid for any type of the fireplace inserts supplied by HAAS + SOHN. The Technical Card provides detailed technical parameters for the particular type.

1. TECHNICAL SPECIFICATIONS

Fireplace inserts are designed for heating in habitable rooms, recreation buildings, work stations and other places to provide thermal comfort. A fireplace insert is used as a closed fireplace while the visual effect - the perception connected with flame - is similar to the sensation of live fire. In comparison with conventional open fireplace, the insert is characteristic with higher thermic efficiency. Another advantage of fireplace insert is the high safety level – no danger from flying brands while flue gases spreading throughout the heated area is limited.

1.1. General requirements on fireplace insert installations

A fireplace insert is either integrated in the fireplace composition or –without casing – may be installed in another way at the particular position. It is located in the particular interior on request and specification by the customer or on architect's design, viewing the concrete arrangements within the room(s) to be heated. The installation and the connection to the vent must be approved by an authorised chimney-sweep company ahead of time. It is recommended to give an order for the installation and lining at a specialist stove-building company. For a basic layout of a single-shell fireplace insert see **Supplement 1**.

Caution! Fireplace inserts may be installed only in rooms and positions risk-free in terms of the position, building conditions and intended use. The walls and the ceiling at the installation area must be free of electric lines. For the rooms with a fireplace insert installed, sufficient air supply for the firing process must be provided. The base area – the place of the installation – must be proper construction and size to allow standard operation of the hearth.

1.2. Heating concept

Fireplace inserts are designed for burning wood, eco-fuel cakes and coal cakes (specific types only) in a burning-through way, characteristic with very good firing conditions. The air within the room is heated thus the thermal comfort is provided by heat convection, in part by heat radiation as well. This way, you can heat up even very cold, long-time unheated rooms very quickly. The heat convection means that the cooler air sucked- in at the area of the bottom part of the insert is heated inside the convective area (comprising of double shell of the heating device or its casing, where the heating process takes place). From there, the heated air is led back in the room via the holes in the upper part of the casing or the insert. The radiation heat is generated by means of surface areas of the stove (metal, ceramics, glass). Due to the construction, the biggest radiation heat source is the glass door.

1.3. Construction design

Fireplace inserts are welded of steel profiles, thickness 2-5 mm. In the middle of the insert, there is a firing chamber that may be closed with the door (equipped with a self-acting element). The door is provided with special large-area glass sheet, thermal resistance up to 800 °C.

The inner space of the firing chamber is usually lined with fireclay brick shapes. The brick shapes are not jointed with any filler (the reason is a protection of the bricks against damage by thermic dilatation). The upper part of the firing chamber is equipped with partitions designed for directing flue gases into a smoke outlet. The partitions may be fixed or movable. Such movable partition may serve as a supporting holder for fireclay brick shapes. At the bottom part of the firing chamber, a simple, fixed cast grate is installed. Before the grate, a barrier is usually provided, to prevent from burning pieces falling out or onto the door (front glass). Under the grate, there is a space designed for ashpan. The remaining space at the bottom part of the stove may be used for spare fuel. With certain models, the smoke flue neck may be adjusted for upper or rear outlet of the smoke: you just release the clamps and rotate the neck of the smoke flue set in the required direction.

The fireplace insert may be a single- or twin-shell model. The twin-shell type is designed to provide direct support to the convective stream flowing through the outer construction of the insert body. The convection holes at the bottom part of the insert allow the air inlet in-between the insert and the casing. The steel construction of the fireplace insert is protected with special refractory paint.

Caution! Fireplace inserts are not designed for continuous heating but for periodical – interrupted (i.e. temporary) operation.

2. FIRING PROCESS

2.1. Fuel quantity and firing process adjustments

Burning wood, wood cakes (or coal cakes – optional) in fireplace inserts is based on burning through the fuel, which means that such firing takes place throughout the whole go of the fuel at a time. In order to provide optimal conditions for easy kindling and burning up, you need enough air being led under the fuel in fire, through the grate: this is the so-called **primary air**, and it must be always adjustable. By increasing temperature of the fuel burning through, certain gaseous components of the fuel evolve that – unless additional air is supplied – would be of no avail in terms of heat energy: therefore, additional air must be provided at the flame level where the firing process connected with those gaseous components may continue. Now, at this stage, the primary air is – in fact – not necessary, while **secondary air** supply is required, or **tertiary air** may be added as well, respectively. The secondary air supply, usually adjustable, improves the firing process and **contributes to the door glass self-cleaning**. The tertiary air supply is designed for general improvement of the burning process and is usually fixed (one cannot regulate it anyhow). If the proportion of the air volumes led into the particular sections of the firing chamber is correct, the burning efficiency is increased while emission of pollutants in the environment is reduced. The layout of the air supply regulative elements is shown in the Technical Card (a part of the documentation supplied with the fireplace insert).

The heating capacity of the heating device depends on the fuel quantity burnt per defined time, fuel quality and firing process efficiency. The data shown in **Chart 2** (heating values) may help you to make a picture of attainable capacity: let's assume that you burn 1 kg of wood per hour, wood moisture is 20%. Further, with higher wood moisture its heating capacity goes down.

In the testing room conditions, adjustability of the heating device was tested, within 30 – 100% of nominal performance. For the regulation, the chimney effect and the fuel quantity were applied. In practice, the heating capacity may be regulated by means of air supply regulating elements (especially the primary air inlet). There is no simple and explicit way to determine the firing process adjustment by means of regulators. There are many aspects to consider – fuel moisture, type of fuel, chimney effect, exterior pressure conditions, etc. Therefore, the firing process (the flame intensity and quality) should be re-adjusted for particular conditions.

You will be able to adjust the firing process to achieve best efficiency after a short time of operation. A detailed chart showing how to adjust the air supply regulating elements is included in the Technical Card. The figures in the chart are the testing results verified by the State Testing Laboratory. The **Chart 1** presents just general information for air supply adjustment.

Fuel	Fuel quantity	Primary air	Secondary air	Tertiary air
		Adjustable	Adjustable	No adjustment
wooden logs and eco-cakes	2 - 3 logs (approx. 2 – 3 kg) 2 - 4 logs (approx. 2 – 3 kg)	Closed or open (depends on local conditions)	Open wide	Fixed adjustment at installation
coal cakes	2 - 3 logs (approx. 2 – 3 kg)		half-open	Fixed adjustment at installation

Chart 1

Our tips for wood burning

- Any time you set the fire, let the primary air regulator open long enough to allow the fuel burning properly.
- Before you re-load, it is recommended to open the primary air regulator wide.
- While burning wood, make sure the wood is dry, maximum moisture 20%.

Our tips for coal cake burning (selected models only)

- To achieve optimisation of the firing process, load the cakes directly onto the grate holes: this way, you support the burning in best possible way.
- Make sure you do not overload: for the heat capacity you may use, i.e. to maintain the heat, a couple of cakes is enough: otherwise the device would suffer from excessive heat. **Coal cake fuel efficiency may reach 6 kWh/1 kg, i.e. by some 40% more than wood!**

2.2. Fuel

For fireplaces, you may burn logs, wood cakes and coal cakes (some models only). The moisture of the wood to be burnt should be lower than 20%, optimally 10%. The rule of thumb is: the less water in the fuel, the higher heating capacity you achieve. For the recommended wood moisture, you may reach it safely if you store the wood in a well ventilated shelter for at least two years. The water content in coal cakes should be specified by the manufacturer. The cakes should be stored in a dry room otherwise they disintegrate. It is recommended to store the wood intended for burning in pieces approx. 3-6 cm (diameter), 20–30 cm (length). **It is forbidden to load and burn coal or charred coal.** In the fireplace, never burn flammable liquids or waste. It is forbidden to burn papering, chipboards, plastic materials, penetrated wood, wood shavings or saw dust. Burning such materials not only is detrimental to the environment but shortens the service life of the heating device as well: you might seriously damage the device or the chimney as well.

Note: The bark, a part of wooden logs, is no issue at all.

Fuel efficiency : selected types of wood at moisture 20%

Wood	Fuel efficiency kWh/m ³	Fuel efficiency kWh/1 kg	Weight kg/m ³
Spruce, fir	1957	4,0	485
Larch	2461	4,0	610
Pine	2280	4,0	565
Oak, beech	2743	3,8	726

Chart 2

3. SAFE OPERATION

3.1. General requirements

While installing and operating stove insert, it is obligatory to adhere to the fire prevention regulations (related to this type of devices) in force in the country of installation.

The device is designed for standard environment. In case of any temporary change establishing any temporary danger of fire or explosion (for example, while installing linoleum flooring, PVC, painting, etc.) it is crucial to put the heating device out of operation IN TIME, BEFORE ANY POTENTIAL DANGEROUS SITUATION MAY OCCUR. At the end of the work, do not start using the fireplace again until the room conditions are brought back to normal (it is recommended to provide fresh air by draught).

3.2. Safe distance between the fireplace insert and flammable material

If you have installed a fireplace insert within the room with flammable objects, flammability Class B, C1 and C2, the safety distance from the front (or side glass surfaces) is **800 mm**; for the other directions, the safety distance is **400 mm**. If the insert is installed within a room with flammable objects, flammability class C3, the safety distances must be **doubled**. Kindly pay attention to the information provided in **Supplement 1 and 2. The most important** installation dimensions are shown in the product name plate.

3.3. Safe distance between the smoke flue and flammable material

The safety distance from the door frame lining and similar constructions made of flammable materials, and from pipeline installations, incl. insulating elements is **200 mm (minimum)**. The safety distance from the other parts of the constructions made of flammable materials is **minimum 400 mm**. This is applied to construction materials, flammable Class B, C1 and C2. (see Chart 3). Kindly pay attention to the information provided in **Supplement 2. More accurate classification is available only if testing is performed for the particular product.**

3.4. Directions for safe operation

For firing or kindling, never use any flammable liquid! It is forbidden to burn any plastic material, wooden material combined with chemicals (chipboard, etc.) or domestic (unsorted) refuse containing plastic, etc.

The insert must be operated by adults only! Never allow children in the room unattended. The surface of the fireplace insert is overheated, especially the glassy components: any contact will cause serious burnt. During the operation, occasional monitoring is required. For safe operation and handling the regulation elements and the door closing devices, use the protective glove (a part of the supply) .

Do not put any objects or tools on the insert while in operation or hot: flammable material may cause fire.

The ashpan must be manipulated with utmost care. The ash may be very hot so there is danger of serious burnt. Hot ash must not be in contact with flammable material – for example, while pouring it into waste container.

The fireplace insert must be operated in compliance with the directions and recommendations in the Operating Instructions. It is forbidden to modify the insert in any way unless approved by the manufacturer.

Flammability class: selected construction materials

Flammability class	Construction materials
A – Incombustible construction materials	Granite, sandstone, heavy concrete (porous), brick, ceramic tiles, special plaster
B - heavy fuels	Akumin, Heraklit, Lignos, Itaver
C1 – hardly inflammable	Hardwoods, Hobrex panels, Sirkolit, hardened paper, formica
C2 – medium inflammable	Chip boards, Solodur, cork parquet, rubber, floor covering
C3 - Flash fuels	Wood-fibre boards, polystyrene, polyurethane

Chart 3

4. INSTALLATION AND CONNECTION TO THE CHIMNEY

Caution! For installation, relevant local regulations must be strictly adhered, including the regulations related to national and European standards for this type of device.

4.1. Connection to the chimney or chimney insert

Connection of the fireplace insert to the chimney vent is subjected to approval by specialist chimney company (ČSN 73 4201:2008), or to approval according to relevant regulations in force in the country where the installation is made. Kindly pay attention to the information provided in **Supplement 2.**

To provide proper function and operation, proper chimney effect in the smoke flue neck is required. For the minimum stack draught, see the Technical Card for the particular product. Insufficient chimney effect results in malfunction of the insert, excessive dirt on the glass, and excessive clogging in the smoke flue system. The general heat capacity of the device is reduced. If you feed the fire while proper chimney draught is not provided, flue gases may spread throughout the room. For this reason, it is strictly recommended to have regular check done by a specialist chimney company and maintain the heating device regularly. If the chimney effect is too high (over **20 Pa**) it is recommended to install a suitable blocking device (for example, flue tube with a block). Excessive chimney draught may cause troublesome operation, for example, too intensive burning, high fuel consumption, damage on the heating device, etc.

Caution! It is recommended to connect fireplace inserts with rear outlet to the chimney by direct connection (without an elbow element). Any other method of the connection should be approved by a specialist chimney company.

4.2 Connecting the stove insert to the venting unit

It is recommended to connect the stove (insert) to a separate chimney vent. A joint chimney vent may be used for the connection only if the safety regulations valid in the country of installation allow doing so. It is forbidden to connect the stove (stove insert) to the same vent used for a gas appliance. The minimum working height of the vent is 5 m. Depending on local conditions, it is possible to connect the stove in the vent with a working height under 5 m providing that the flue way calculation demonstrates that such a height is satisfactory.

Caution! (Provisions CSN 73 42 01: 2008)

The smoke flue vent diameter must not exceed the diameter of the chimney vent; it must not be narrowed towards the chimney, either. If the calculation demonstrates that the vent diameter of the smoke flue and chimney can be smaller than the flue neck diameter of the device, the diameter of the smoke flue will be reduced just after the flue neck of the device, by means of a short transition or abrupt.

4.3. Directions for smoke flue installation and safety

Connect the smoke outlet neck with the chimney in the shortest possible way so that the length of the smoke path is no longer than 1.5 m. The smoke pipes and the elbow piece must be tightly connected, overlapping at least 60 mm. Pay special attention to the fact that the joints must agree with the flue outflow. The joint between the smoke flue and the smoke outlet neck must be drilled together and fixed with a rivet or pin; the same is applied for the smoke pipes and the elbow. The hole (entrance point) in the chimney must be provided with a metal stress ring (proper diameter). The smoke flue should ascent towards the smoke uptake at angle approx. 10°.

4.4. Installation of the fireplace insert within the room

Before any installation work is started, you need to verify the floor (ceiling) load capacity. The load conditions for the particular type of the device must be met (depending on the particular weight), including the weight of the casing. It is recommend to contact a statics specialist. The fireplace insert must be installed on a heat insulating base that overlaps the stove ground plan dimensions on the sides and in the rear by at least **400 mm**; **the overlap in the front (the direction of the feeding opening) is 800 mm**. If a metal base is used, the thickness must be **at least 2 mm**.

For safety distances from the outer surface of the insert body and the smoke flue, see Chapters 3.2 and 3.3.

Caution! Make sure you provide space enough for easy approach to the heating device, smoke flue and chimney for the purpose of cleaning.

4.5. Cleaning the heating device and chimney

It is necessary to provide approach to the piping (smoke path) for occasional cleaning by means of, for example, a removable part of the casing at the area of the smoke flue. We recommend you to advise of the requirement the company whose technicians will install the fireplace insert for you. Further, approach in the chimney for occasional cleaning is required as well.

By regular cleaning of the smoke pipes and the firing space in the fireplace insert, you may optimise the performance of the heating system and guarantee a trouble-free function and operation. By regular chimney cleaning, you avoid inflammation of fouling solid particles caught on the chimney walling.

4.6 Fire in the chimney

In case of fire in the chimney, put out the fire in the stove immediately: remove the burning fuel remnants with a shovel (put them aside in a suitable non-flammable container) and call the fire brigade immediately: Call the fire brigade or the integrated rescue system centre.

4.7. External combustion air supply

For the firing process, enough fresh air supply is needed. While firing wood, the device needs up to 15 m³ of fresh air per hour. In case of newly built houses, the insulating materials used in the house result in low airiness coefficient, due to plastic windows, etc.). Another issue may be exhaust devices or other heat installations in operation in the room or within the space where the fireplace is installed. In such well-insulated houses, the quality of the firing process is lower, being accompanied with tarring and smoke path clogging (and/or smoke penetration and spread in the room). Make sure that the air supply in the room is sufficient, by open windows or door in the next, better ventilated room. It is more convenient if you – along with the installation of the heating device – install a ventilation hole to provide air supply, equipped with a regulating grate (should be protected against clogging). It is recommended to verify whether the air supply is sufficient, by - for example – using the procedure **TPG 704 01 “Gas consumption devices and appliances with gas fuel installed in buildings“**.

4.8. External air supply system

Modern fireplace inserts are designed with an external combustion air supply. This way, enough air is supplied for making the firing process perfect, especially in case of houses with low airiness coefficient (well insulated from the external environment due to construction elements reducing natural air circulation (plastic windows, doors etc.). Such external additional air supply should be connected to the system chimney, whose part is a vent. This is offered by means of, for example, a chimney system made by SCHIDEL. Another option is a connection with space where the air circulation is sufficient – e.g. by means of a passage through the wall into the exterior. The best solution for the particular house should be suggested by the specialist chimney company or the company responsible for the installation of the fireplace insert.

5. OPERATING INSTRUCTIONS

5.1. Before first operation

If the fireplace insert is supplied without casing

Before the first putting into operation, you have to remove labels from the glass, accessories found in the ashpan or inside the hearth, including transport clamps etc. Following the illustration in the Technical Card, check that the movable partitions designed for directing the flue gases, fireclay brick shapes or the barrier are located properly (they may have moved out of the position during the transportation or installation work). If you find any wrong position, correct it; otherwise, the heating device might not work properly.

When the fireplace insert has been positioned and connected to the chimney system, make (not very big) fire, maintaining it for approx. one hour.

As soon as the device gets cold again, it is possible to install the outer lining.

If the complete fireplace set is supplied

Following the instructions for installation, place and connect the fireplace insert to the chimney system (including the installation of protective sheets –if used – and insulation of the smoke piping). After that, install the lining (follow the instructions and illustrations). Then, install the fireclay layer in the hearth of the fireplace insert. For the very first fire, use smaller quantity of wood, maintaining the fire for at least one hour.

The insert surface layer is provided with fire-resistant paint being softened during the first fire made in the stove to become harder afterwards. During the soft phase, pay special attention to danger of damage on the surface by touching it with fingers, tools, etc. For the very first use, the initial fire should be very small, to “warm up” the device gradually: it is recommended to load smaller quantities to establish lower temperature. All materials need the initial lower- temperature phase in order to “get used to” the thermal stress. By such slow heating up, you avoid cracks in fireclay bricks, likely damage on surface paint or material deformation in general. **The odour generated during the paint hardening process at the first putting into operation is just temporary – however, it is recommended to ventilate the room intensively.** If pets are present, move them to another room for a while.

With the models equipped with the glass door comprising of three parts, check the segments for gaps (which may be formed during the transport or the first use).

What to do if you find a gap between the glass segments: Partially release the holder nuts. Move the glass segments (carefully!) closer to each other: the edges should touch slightly. Slowly and carefully, tighten up the holder nuts.

5.2. Setting the fire

To set the fire easily, follow this procedure: Put 2 or 3 smaller wooden logs onto the bottom or on the grate. Add paper or permitted fire lighters, then brushwood, small firewood and thicker logs (the last layer). You should always load a bigger quantity (i.e. enough wood, which means up to approx. 2/3 of the height of the fireclay (vermiculite) lining. By loading such bigger quantity, you establish time long enough in order to heat the chimney thus set the proper conditions for the chimney function. Open the primary air regulator wide (maximum). Sometimes it is good to reduce the secondary air supply at this moment – the fuel catches the fire better. After setting the fire, keep the stoking door shut all the time. As soon as the wood flares up properly, use the air supply regulators to set not very intensive, rather slow burning. To adjust the flame and the burning, you may apply the information specified in the Technical Card or Chart 1.

You may poke the fire when needed, using the fire hook or the poking lever (if installed).

Caution! The stoking door (the firing chamber) and the ashpan door (if installed with your particular model) must be kept shut all the time, except setting the fire, fuel reload or ash removal.

Caution! After every standby for a longer time, before you set the fire again, **check the fireplace insert** for clearness and cleanness of the smoke flue, chimney and firing area.

5.3. Feeding the fire

To prevent the smoke spreading throughout the room during the fire feeding, the following is recommended: Approx. 5 to 10 seconds before you open the stoking door, open the primary air regulator wide. Then, open the stoking door a bit only, wait for a couple of seconds to allow the smoke exhausting through the chimney. After that, open the door wide. Pay attention to the door any time you open it: do not allow live cinder fall out. When you reloaded the wood, shut the stoking door. When the fuel burns up (no carbon black flame), bring the regulating system back in the previous position (or close the regulator, respectively). While feeding the fire, make sure the wood does not exceed the level of the fireclay (vermiculite) lining within the firing area. The quantity of the fuel reloaded should be more or less the same as specified in the information provided about the hourly consumption for the particular model of the heating device (see the Technical Card). If you overload the stove with excessive fuel, you may cause permanent damage to the insert construction.

Caution! If you want to avoid unnecessary smoke spreading throughout the room during the feeding, reload the wood after the previous load has burnt up to cinders.

5.4. Glass cleanness

The cleanness of the transparent glass depends on the type of the fuel, proper combustion air supply (**this is applied especially to the secondary air**), the chimney effect and – last but not least – on the way how the fireplace insert is operated. It is recommended to load one layer of the wood only: the logs should be laid evenly, farther from the glass (as far as possible). The rule is the same for coal cakes as well (keep the distance 5 to 0 mm between them). If the glass is dirty, we recommend to increase the firing intensity by opening the primary air regulator, which usually supports the self-acting cleaning process.

5.5. Operation during temporary period and at worsened weather conditions

For temporary periods, for example, during the time when outdoor temperature is above 15°C, during rainy and wet days, in case of gusty wind, etc. the chimney effect may worsen thus the smoke is not led away in full as usual. Therefore, during such period, you should operate the fireplace insert with smallest possible quantity of fuel, to allow improving the firing process and the chimney effect by opening the air inlets in case you need to make adjustments.

5.6. Fireplace insert function adjustment

Some models are provided with the so-called blind element that serves as the chimney effect conditioner as well. After removal of such blind element, those models must be completed with warm-water exchanger allowing connection to heating bodies to provide heat in adjacent rooms or with a water back boiler. A warm water exchanger may be supplied as special accessory (detailed instructions for operation and installation provided). Order the installation of fireplace insert with warm water exchanger at specialist company (ask for installation following from the project documentation).

Caution! A fireplace insert equipped with a warm water exchanger must not be operated without the connection to the warm water distribution system or the water filled, or without anti-freezing mixture, respectively.

For any installation of warm water pipeline, the requirements on heat systems and networks in buildings valid in the country of installation must be adhered to.

Related regulations:

Heat systems in buildings – Safety devices

Heat systems in buildings – Design and installation

Heat systems in buildings – Hot water production

Heat systems in buildings – Designing hot water heat systems

Heaters using fossil fuel designed for dwelling space

Built-in heat devices and stove inserts using solid fuel

Caution! If you install a fireplace insert with a warm water exchanger, before lining and before first fire, you must connect the exchanger in the heating system operated in order to check the warm water distribution system for leak.

5.7. Ash removal

Depending on the length and the intensity of the firing process, you need to use a fire hook or poking lever (if installed with the particular model) in order to knock the ash down the grate to the ashpan.

Monitor the content of the ashpan - do not allow too much ash in it. Excessive ash may block the air supply under the grate thus causing problems at fire setting or burning.

Always empty the ashpan when cold. The best approach is to empty the ashpan just before you start preparing the next fire. **With some models, the ashpan is located just under the grate (impossible to take it away on the side). If this is the case, empty the ashpan only if cold, while the heating system is not in operation.** Ash from wood may be used for composting or for fertilizing.

Caution! Before you touch the ashpan to empty it, check it for fire brand. Prevent any likely fire in the dustbin.

6. CLEANING AND MAINTENANCE

6.1. Cleaning

The fireplace insert (cold) needs cleaning at least once a year (after the season), or twice or more (if needed). During the cleaning, you should remove any dirt caught in the smoke flue, the firing area and on the partitions. Loose parts of the fireclay lining should be repaired (i.e. replaced). Check the fireclay lining for integrity even during the heating season. The gaps between the brick shapes are designed for heat dilatation, to avoid brick cracking. Therefore YOU SHOULD NOT fill any sealing in the gaps (as it used be before with older heating devices).

Cracked fireclay bricks do not lose the function unless they are completely fallen out of the position!

In the course of the cleaning procedure, we recommend you to remove all movable partitions (for easier access in the area above them). To clean the glass, apply standard cleaning agents designed for cleaning stove, cooker or oven. Use a soft cloth or paper, or special agents designed for cleaning fireplace glass. Only clean the glass when cold. For cleaning the painted surface, never use water: it is recommended to clean such surface with sponge or soft flannel cloth.

Caution! With selected types of fireplace insert, the vertical side of the firing area is provided with VERMICULITE. The same material is used for some chimney effect conditioners. The material is irreparable. In case of any damage, just have it replaced. Vermiculate products are characteristic with top heat-insulating parameters and good resistance to cracking. The resistance to abrasion is somehow lower so it is recommended to keep this in mind while reloading and cleaning.

6.2. Sealing lines and tapes

Contact areas of doors and glass (or other parts of the heating device) are provided with a special glass-ceramic sealing line (tape) that is resistant to high temperatures. We recommend you to check the tape for integrity, and have it replaced if necessary.

After some time, any newly installed sealing tape lays flat so it is recommended to check the tightness (the glass tightly installed in the door construction) after approx. 3 months of usage. If you find any release, tighten the glass holders (carefully!)

6.3. Spare parts

In case of repair, use only original spare parts recommended by the manufacturer, see **Chapter 10.3** (Recommended spare parts). Identify the spare part with use of the Technical Card (a part of the supply).

7. WHAT TO DO IF... ...Do you do it yourself?

Problem	Cause	Corrective action
Malfunction (weak fire, weak chimney effect) or excessive smoke during reloading or during the firing	Chimney or smoke flue sealing (malfunction, "false" air is being added).	Contact a chimney sweep (ask them to check the chimney). For example, new sealing for the chimney door is needed. Adjust the positions of smoke pipes or replace them if damaged.
	Chimney effect bad or not working	Ask the chimney or stove specialist technician for inspection to find out the reason and the solution (e.g. cleaning the chimney, remove the smoke flue reduction elements, higher chimney, more air in the room, etc.
	The door of another heating device connected to the same chimney is open	Shut the door
	Chimney cleaning holes are open	Close the cleaning holes
	Smoke flue elements or other parts of the heating system are dirty or clogged.	See 6.1.
	Insufficient fresh air supply	See 4.7.
	Worsened weather conditions	See 5.5.
	Wrong type of fuel was used for burning	Provide proper kind of fuel, see 2.2.
	Impossible to heat up the fireplace insert within expected time	Wrong position of the wood logs inside Not enough fuel to set fire
Primary air supply inlet is closed		Open the primary air regulator or turn down the secondary air regulator, respectively
The room is not heated enough	Inadequate requirement on the heat capacity (performance of the fireplace insert is too low)	Contact the specialist Reduce the heat loss (for example, provide better heat insulation)
	Smoke flues and insert are dirty	See 6.1.
	Chimney effect is too low	See 4.
	Fireplace insert is operated in a wrong manner	Heating device adjustment is not optimal, see 2.1.
Excessive performance of the fireplace insert	Fireplace insert is operated in a wrong manner	Heating device adjustment is not optimal, see 2.1.
	Ashpan door is a bit open	Shut the door
	Door or ashpan sealing is damaged	Replace the door sealing
	Excessive chimney effect	See 4.
smoke	Chimney effect is too low	See 4.
	Protective paint is being hardened/ the stove is dirty, dusty	Allow the paint hardening process finish – the smoke and odour will disappear in a short time / while cold, clean the device outside

Window is getting dirty	Sometimes is difficult to find the reason but, usually one of the following is found: wrong type of fuel, wrong adjustment of the firing process, weak or temporarily weak chimney effect, door sealing loosen	Rule: Clean the door from time to time (depends on the type of the fuel used), see 5.4. . If coal cakes are used, the door needs cleaning more often than with wood
	Chimney effect is too low	See 4.
	Too much fuel in the firing area	Only load correct quantity, see 2.1. and 5.3.
	Wet fuel was loaded	Use only well-dried fuel, see 2.2.

8. FREQUENT PROBLEMS AND QUESTIONS

8.1. Cracked (released) fireclay (vermiculite) brick in the burning area

It is emphasised that cracked fireclay bricks do not lose their function unless they have fallen out, so there is no reason to replace them while cracked only. In case of replace needed, order the components at your sales representative or manufacturer's address. Please specify the type and the serial number and the fireclay ID number (see the Technical Card).

Procedure If you need to replace the side bricks, remove the upper partition or remove the fireclay holders and take the damaged brick away. Sometimes, you need to remove the cast grate with bricks at the bottom. For the installation, use the same procedure (reverse). Make sure you place the components back in exact positions (follow the Technical Card).

Caution! Do not put the stove in operation if (even a part) of the lining within the burning area falls out. There is danger of burning the construction through.

8.2. Broken glass

The door glass is made of special glass-ceramic material, characteristic with top heat resistance. **Do not use standard window glass!**

Procedure: There is no need to dismantle the whole door. You should only unscrew the holders and remove the glass then easily. When you install the new piece, make sure the new glass is seated evenly. The contact surface between the glass and the door must be provided with a sealing tape. Do not replace the sealing tape if it is in good condition. Tighten the glass holders back slowly and carefully to avoid cracking the new glass by excessive tension.

Caution! Some types of the fireplace insert are not provided with the sealing tape along the whole perimeter.

8.3. Partitions to control the chimney effect

To clean the insert or replace fireclay (vermiculite) bricks, first remove the movable partitions (**if installed, see Technical Card**). This way, you make your way to the cleaning or replacement job. Keep in mind that some types of the partitions are designed for holding the bricks at the position as well. Make sure you do not tilt them or let them fall out and break. Install them back in their original positions.

Disassembly: Lift the movable partition on one side a bit – this way, the other end is lowered. Move the partition aside to allow taking it out of the device.

Assembly: Use the same procedure (reverse order). Insert the partition into the device and find the previous position. Check the final position with the Technical Card!

8.4. Blind element substituted with exchanger (optional)

Disassembly: Use a wrench (proper size) to unscrew the nuts from the blind element. Remove it from the insert construction.

Assembly: Before you install the exchanger, carefully clean the contact area. Remove any remaining parts of the previous sealing after the blind element has been taken away. Provide undamaged sealing under the exchanger. Tighten the nuts evenly to provide good tightness along the whole exchange flange.

9. PRODUCT LIABILITY AND SERVICE

9.1. General

Providing that all directions and recommendations in the Instructions for Installation, Operation and Maintenance are respected, the manufacturer (supplier), company HAAS + SOHN Rukov s.r.o. provides guarantee for 24-month period from the takeover for parameters and characteristics of the product as specified in relevant technical standards, in the Instructions and the data shown in the nameplate.

9.2. Conditions for guarantee

The guarantee covers free-of-charge repair of the fireplace insert or parts or components (the subject of complaint, if any) providing that the cause of the defect is defective material or craftsmanship.

9.3. Guarantee and post-guarantee service

Guarantee and post-guarantee service is provided by importer companies or contractual partner service institutions.

9.4. Claim rejected

The warranty is not related to damage or defects of the device or its components caused by:

- Contact with chemical substances or physical contact causing damage during the transport; improper storage; erroneous installation or operation in an improper manner (for example, cooling with water, dirt from food, water condensate, etc.)
- Wrong product installed (overheating or under-heating in the room)
- Construction and legal requirements not adhered
- Wrong installation or connections
- Poor or too strong chimney effect (the connections must be in conformity with the standards currently in force)
- Unauthorised alteration or additional modification of the heating system, especially the firing area or smoke flue system
- Unauthorised persons interference (service work by unauthorised persons)
- Instructions for operation not adhered
- Additional built-in accessories or spare parts not manufactured by HAAS + SOHN Rukov s.r.o.
- Use of inappropriate kind of fuel
- Erroneous operation, device overload (e.g. the ashpan door open) resulting in damaged construction (e.g. burnt-through partitions, construction deformation, etc.)
- unprofessional manipulation, mechanical damage by excessive mechanical force
- Lack of proper maintenance or use of inappropriate cleaning agents
- Force majeure (floods, etc.)

9.5. How to make a claim

Send a written claim to your sales person by letter, fax or e-mail. Please specify the product model, year of manufacture and serial number (the data from the name plate, at the rear). It is recommended to copy the nameplate data in the Table below. This way, you can find easily if needed.

HAAS+SOHN Rukov s.r.o, SNP 474, 408 01 RUMBURK, CZ
FIREPLACE INSERT - TYPE: SERIAL NUMBER: YEAR OF MANUFACTURE: OUTPUT PERFORMANCE:

If you make a claim, kindly provide your address, phone number and description of the defect. Ask the seller for warranty at the purchase. The service centre shall deal with the problem in shortest time, suggesting the place and time of the service action to the customer. In case of request on the product replacement or purchase contract made void, the respective provisions of the Civil Code and the Claim Code will be applied.

9.6. How to order spare parts

You can order spare parts and accessories at your local distributor – dealer, or at our partner organisation.

10. MISCELLANEOUS

10.1. Accessories supplied with the insert

The fireplace insert has been delivered with accessories: protective glove to touch the regulating elements, ashpan drawer, Instructions for Installation, Operation and Maintenance, Warranty, Technical Card, Instructions for installation of fireplace set (if ordered).

10.2. Special accessories (on order)

1. Smoke flue pipes, diameter 160 mm and 180 mm (length 0.25 m)
2. Smoke flue elbow, diameter 160 mm and 180 mm (90°)
3. Chimney stress ring, diameter 160 mm and 180 mm
4. Baskets
5. Fireplace tooling (special offer)
6. Cleaning agent (glass)
7. Fire protection barrier set

10.3. Recommended spare parts

Spare parts available on order

1. Fireclay brick shapes and VERMICULITE boards for the firing area
2. Ashpan drawer
3. Stoking door glass
4. Cast grate
5. Sealing tape glue
6. Sealing tapes
7. Repair spray
8. Decorative and regulating elements (rods, handles, regulators)
9. Sealing tape glue

10.4. Package and waste disposal

The fireplace insert and the lining set are supplied on a wooden transport pallet and protected with wooden crate. The insert and the lining set are protected against weather with PE foil. Stabilised position and integrity of the package for the period of storage and transport is provided by means of metal or plastic tape.

Package material disposal Use the wooden crate and the pallet for burning. Sort the steel tape for the waste collecting point. Sort the PE foil to be recycled.

Disposal: insert body and stone lining. For the disposal after the service life, sort the fireclay, vermiculite panels, glass and sealing tapes as solid communal garbage. Sort the metal corpus and other metal components for the waste collecting point.

10.5. ES Declaration of Conformity and CE Certificate

ES Declaration of Conformity is issued with all products, following from the Report on initial type testing in compliance with EN 13 229 : 2005 + A2 : 2004 and CE Certificate. The Report on initial type testing and the CE Certificate are in accord with Directive 89/106/EHS, issued by a notified body.

Notified testing institutes (verification of the products manufactured by HAAS + SOHN: Strojirenský zkušební ústav, s. p. (Testing Institute of Engineering) ,ES 1015, AO 202, Hudcova 56 b, 621 00 Brno, Czech Republic.

Rhein – Ruhr Feuerstätten Prüfstelle (RRF) Essen, Germany.

The manufacturer declares that the fireplace insert as specified is in conformity with the requirements of the Directive 89/106/EHS. Under the standard conditions, the product is safe providing that it is operated and used for the purpose as designed by the manufacturer.

The manufacturer guarantees the conformity of all products in the market with the technical specifications and identical requirements.

10.6. HAAS+SOHN Rukov s.r.o Products and Manufacturing Programme

Company HAAS+SOHN Rukov is a Czech company with participation of foreign capital. The company specialises in manufacture and sale of fireplace sets and fireplace inserts. The products are designed for burning wood, eco-wood cakes or coal cakes (optional).

Manufacturing Programme

- Fireplaces
- Fireplaces with warm water exchangers
- Tiled fireplaces
- Tiled fireplace with warm water exchanger
- Fireplace insert and fireplace sets
- Fireplace inserts with warm water exchangers and fireplace sets

MISCELLANEOUS

- Fireplace tooling and baskets
- Accessories (smoke flue pipes, elbow pieces, chimney stress rings, etc.)
- Other special products

Caution!

The above recommendations and technical specifications follow from the requirements in technical standards applied for the certification of the product (EN 13 229:2005+A2: 2004) in conformity with Directive 89/106/EEC.

11. SUPPLEMENTS

1. Technical Card and Warrantee

2. Supplement 1

- o Layout for installation of single-shell fireplace insert

3. Supplement 2

- o Example of position of the protective barrier and smoke flue
- o Passage of the smoke flue through the fireproof wall Clearance between the insert and the surroundings

LAYOUT FOR INSTALLATION OF SINGLE-SHELL FIREPLACE INSERT

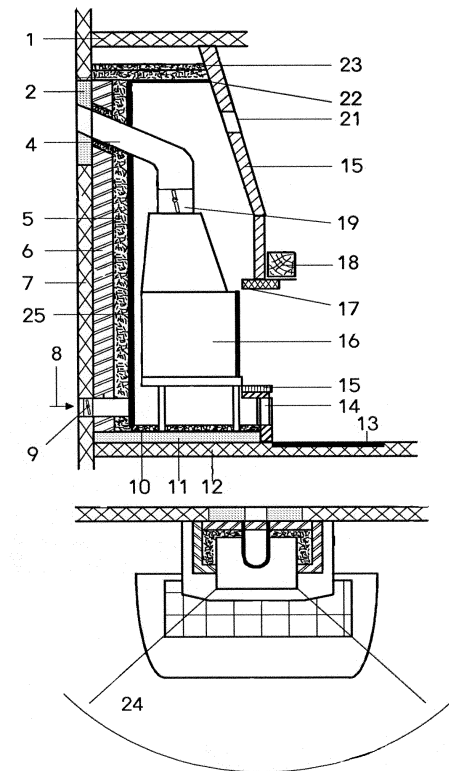

1.	Protected ceiling from flammable construction materials or bearing construction element	14.	Convection air inlet (circulating air)
2.	Insulated area – connection of the smoke flue to the chimney	15.	Fireplace insert casing
4.	Smoke pipes (steel)	16.	Fireplace insert
5.	Heat insulating layer	17.	Bearing frame
6.	Casing	18.	Decorative girder
7.	Protected wall made of fireproof construction material or bearing element (concrete or iron-concrete)	19.	Throttling valve
8.	External combustion air supply system	21.	Heated air output grate
9.	External air supply valve	22..	Bearing element
10.	Heat insulating layer	23.	Heat insulating layer
11.	Bearing plate	24.	80 cm - emission of heat
12.	Protected base plate (flammable material) or bearing construction element	25.	Metal sheet (convection air chamber)
13.	Shielding barrier protecting the floor (fireproof material)		

EXAMPLE: PROTECTIVE BARRIER FOR THE HEATING DEVICE AND SMOKE FLUE (dimensions in mm)

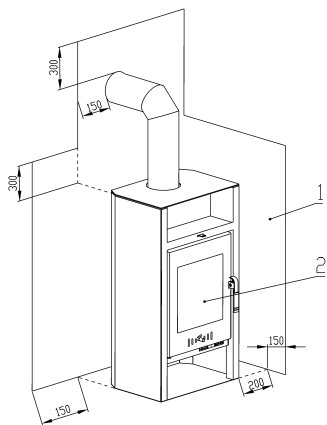

- 1 – Protective barrier for the heating device and smoke flue protecting surrounding constructions against heat
- 2 – Hole for feeding and ashpan

PASSAGE THROUGH THE FIRE PROOF SMOKE FLUE WALL (dimensions in mm)

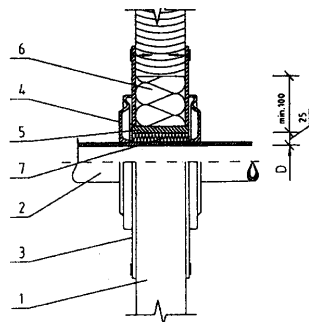

- 1 – Wall
- 2 – Smoke flue system
- 3 – Cover (fireproof, non-metal)
- 4 – Rosette
- 5 – Protective pipe (fireproof, non-metal)
- 6 – Insulating filler I (fireproof, e.g. glass fibre)
- 7 – Insulating filler II (fireproof, e.g. filler designed for stoves)

SMOKE FLUE CONNECTION IN THE CHIMNEY BODY HOLE

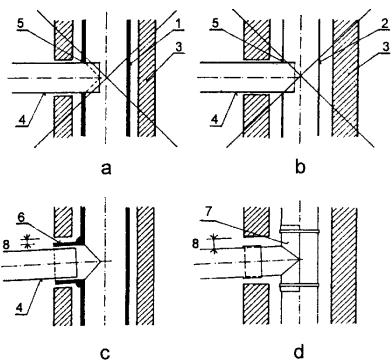

- 1 – Ceramic (metal) insert
- 2 – Metal chimney body
- 3 – Chimney walling
- 4 – Metal smoke flue system
- 5 – Hole in the chimney body
- 6 – Sealed branch to the chimney body
- 7 – Shim, fixed to the body with metal tapes
- 8 – Dilatation gap between the brick shape and the chimney walling

CORRECT – see. c, d **WRONG** – see a, b

CLEARANCE BETWEEN THE INSERT AND THE SURROUNDINGS

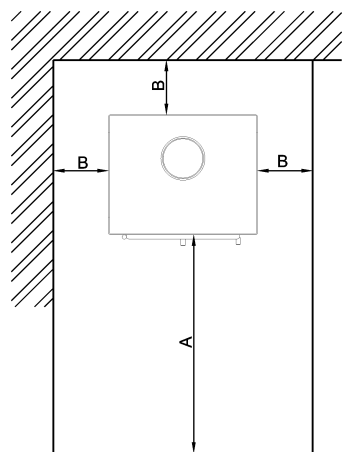

Minimum clearances
 $A \geq 800$ mm
 $B \geq 400$ mm